

ESSIEUX CAOUTCHOUC NON FREINÉS

UNBRAKED RUBBER SUSPENSION AXLES

de 500 kg à 1300 kg - CORPS GALVANISÉS DE SÉRIE



Rappel : Le PTAC d'une remorque non freinée est limité à 750kg - Voir réglementation en vigueur

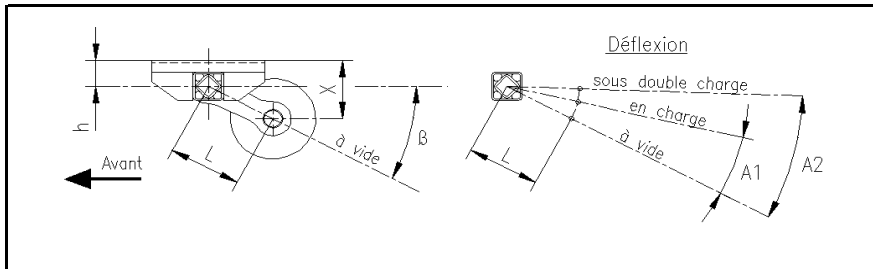
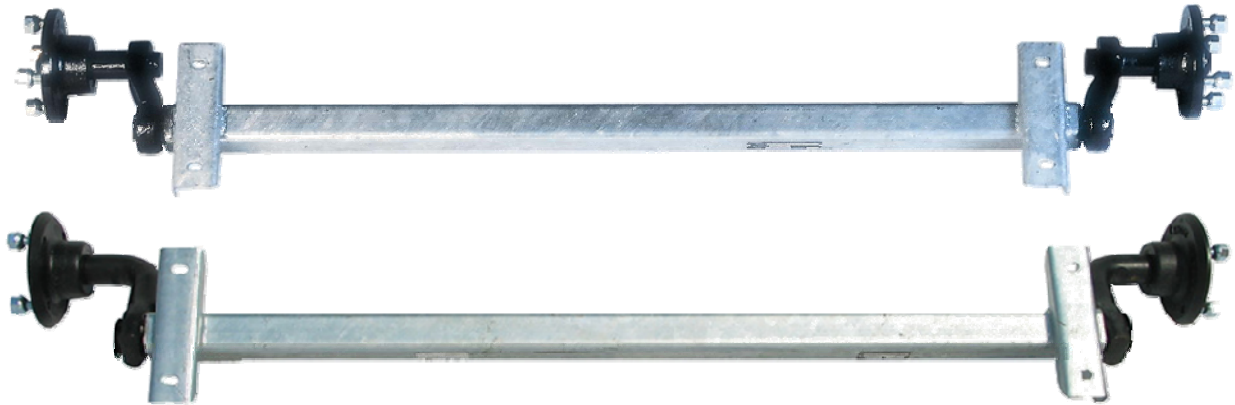

CHARGE	kg	500	650 - 750	900	1100 - 1300
A1	degré	10	15	17	19
A2	degré	21	26	27	32

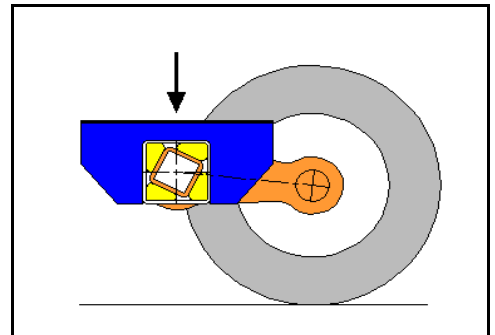
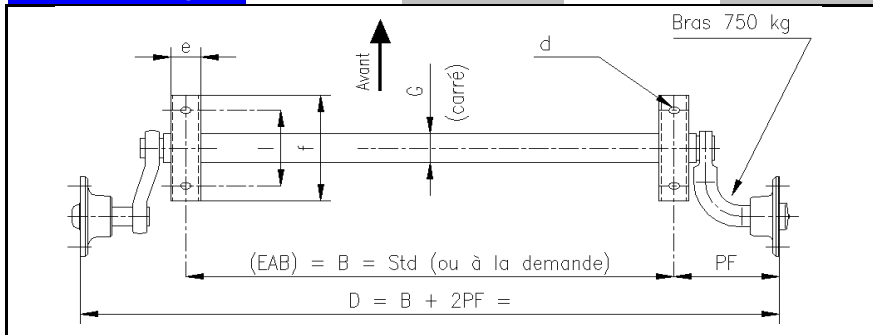
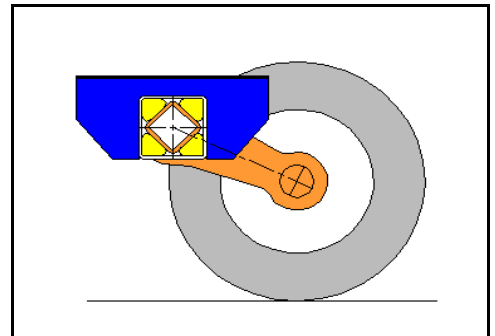

RÉF.	CHARGE	MOYEU	B (STD)	2PF			BRIDE			X	Bras	β	Corps	Poids
	kg	Perçage	mm	mm	l	d	e	f	h	mm	L	degré	G	kg
3637110	350	4x100	1100	450	160	13x21	60	225	55	123	145	28	60	24
3025110	500	4x115	1100	280	160	13x21	50	200	34	90	145	23	60	19
3065110	500	4x130	1100	350	160	13x21	50	200	34	90	145	23	60	25
3028110	650	4x130	1100	350	160	13x21	50	200	55	123	160	25	60	26
2882110	750	4x130	1100	420	160	13x21	60	225	55	123	145	28	60	29
2882116	750	4x130	1165	420	160	13x21	60	225	55	123	145	28	60	30
2882120	750	4x130	1200	420	160	13x21	60	225	55	123	145	28	60	30
2882140	750	4x130	1400	420	160	13x21	60	225	55	123	145	28	60	32
2882171	750	4x130	1710	420	160	13x21	60	225	55	123	145	28	60	35
3201000	900	4x130	-	432	160	13x21	60	225	65	133	160	25	80	41
3202000	1100	4x130	-	432	160	13x21	60	225	65	133	160	25	80	46
3203000	1300	4x130	-	432	160	13x21	60	225	65	133	160	25	80	46

AUTRES PERÇAGES 4x100 : SUR DEMANDE

Les indications contenues dans le présent catalogue n'ont aucun caractère contractuel. Nous nous réservons toute modification nécessitée par l'évolution de nos produits.

(11/2010)

ESSIEUX CAOUTCHOUC FREINÉS

BRAKED RUBBER SUSPENSION AXLES

de 750 kg à 1300 kg - CORPS GALVANISÉS DE SÉRIE



Longueur à la demande ou livrable en paire de 1/2 essieux

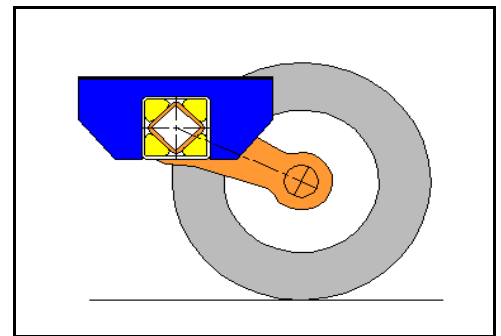
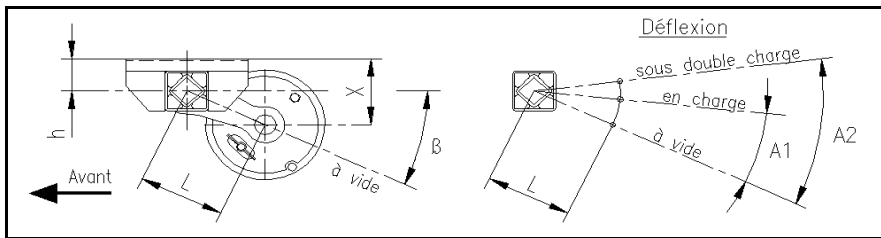

CHARGE	kg	750	900	1100 - 1300
A1	degré	15	17	19
A2	degré	26	27	32

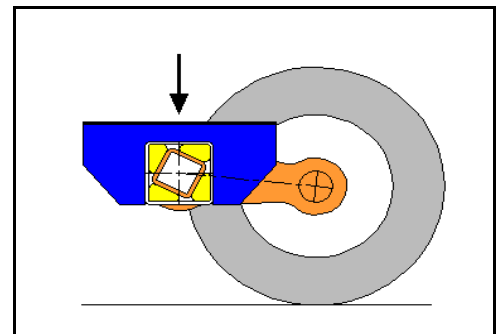
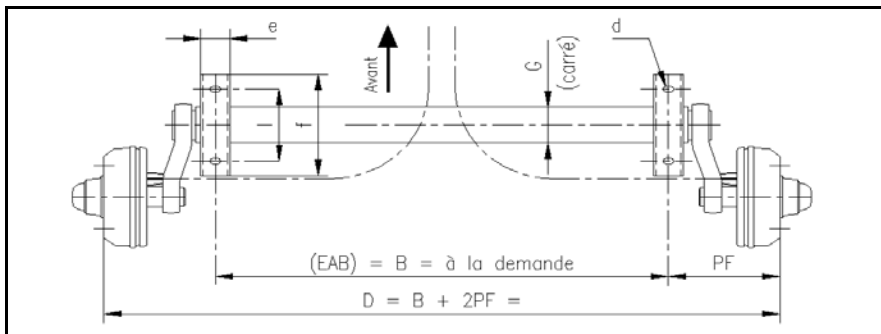

RÉF.	CHARGE kg	MOYEU Perçage	FREIN	2PF mm	BRIDE					X mm	Bras L	β degré	Corps G	Poids kg
					l	d	e	f	h					
2882R56	750	4x130	160x35	430	160	13x21	60	225	55	123	145	28	60	39
3181R56	900	4x130	160x35	430	160	13x21	60	225	65	133	160	25	80	55
2988R47	1100	4x130	200x50	455	160	13x21	60	225	65	133	160	25	80	62
2989R47	1100	5x140	200x50	455	160	13x21	60	225	65	133	160	25	80	62
2985R47	1300	4x130	200x50	455	160	13x21	60	225	65	133	160	25	80	62
2986R47	1300	5x140	200x50	455	160	13x21	60	225	65	133	160	25	80	62

PERÇAGES 4x100 et 5x112 : SUR DEMANDE

TOUS NOS ESSIEUX SONT ÉQUIPÉS DE FREINS KNOTT (homologués T.Ü.V.)

ESSIEUX CAOUTCHOUC FREINÉS - "SURBAISSÉS"

DROPPED BRAKED RUBBER SUSPENSION AXLES

de 900 kg à 1300 kg - CORPS GALVANISÉS DE SÉRIE



Longueur à la demande ou livrable en paire de 1/2 essieux

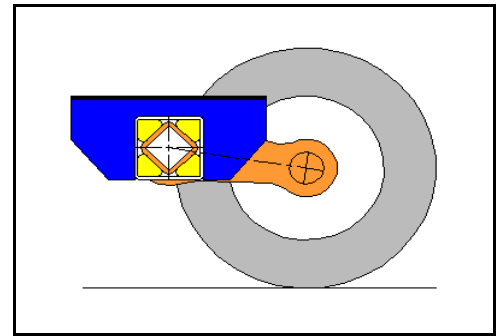
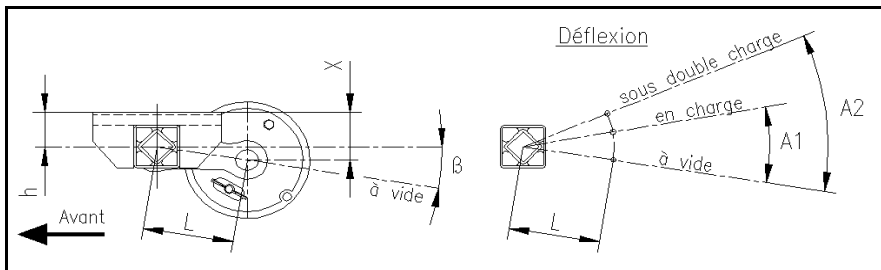

CHARGE	kg	900	1100 - 1300
A1	degré	17	19
A2	degré	27	32

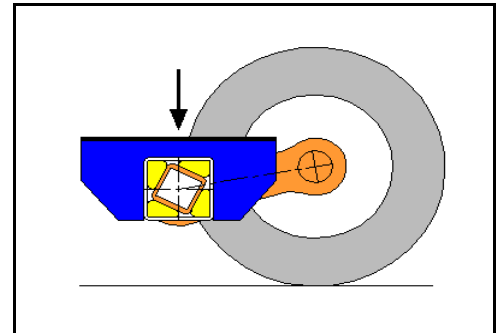
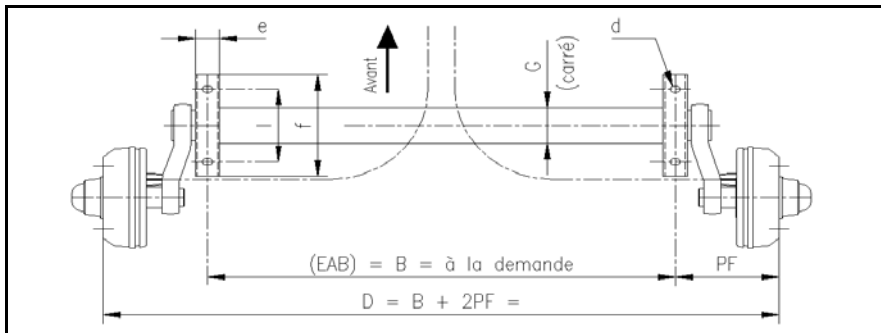

RÉF.	CHARGE kg	MOYEU Perçage	FREIN	2PF mm	BRIDE					X mm	Bras L	β degré	Corps G	Poids kg
					l	d	e	f	h					
3182R56	900	4x130	160x35	400	160	13x21	50	225	65	90	160	9	80	55
3034R47	1100	4x130	200x50	425	160	13x21	50	225	65	90	160	9	80	62
3035R47	1100	5x140	200x50	425	160	13x21	50	225	65	90	160	9	80	62
3036R47	1300	4x130	200x50	425	160	13x21	50	225	65	90	160	9	80	62
3037R47	1300	5x140	200x50	425	160	13x21	50	225	65	90	160	9	80	62

PERÇAGES 4x100 et 5x112 : SUR DEMANDE

TOUS NOS ESSIEUX SONT ÉQUIPÉS DE FREINS KNOTT (homologués T.Ü.V.)

ESSIEUX CAOUTCHOUC FREINÉS - "SURBAISSÉS"

DROPPED BRAKED RUBBER SUSPENSION AXLES

de 1500 kg à 1800 kg - CORPS GALVANISÉS DE SÉRIE

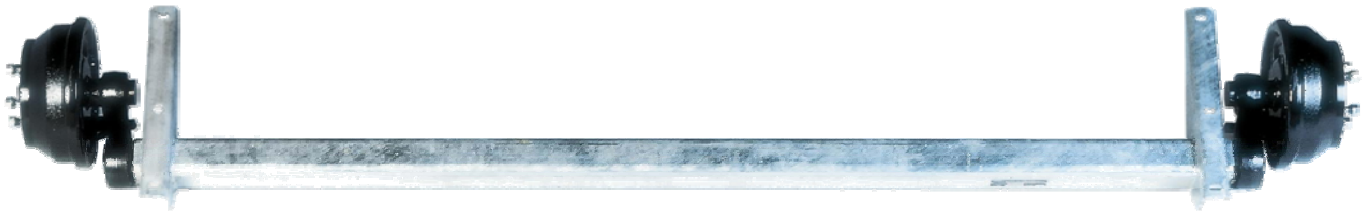

Longueur à la demande ou livrable en paire de 1/2 essieux

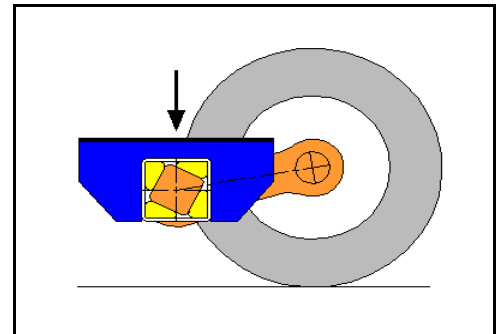
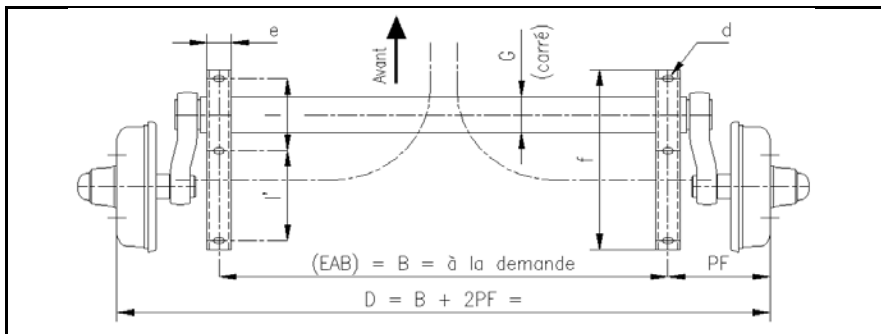
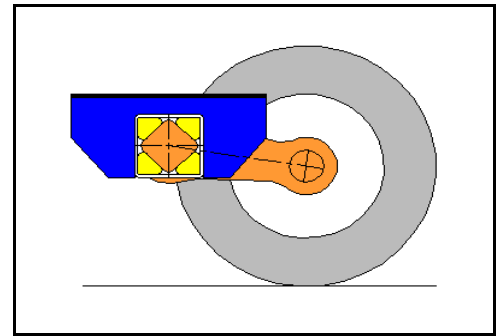
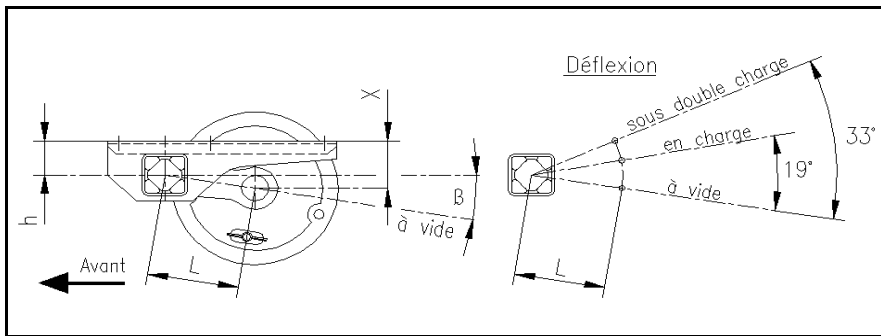

RÉF.	CHARGE kg	MOYEU Perçage	FREIN	2PF mm	BRIDE						X mm	Bras L	β degré	Corps G	Poids kg
					l	l'	d	e	f	h					
3076R47	1500	5x140	200x50	440	160	200	13x21	50	400	65	90	160	9	80	80
3074R40	1600(1)	5x112	250x40	475	160	200	13x21	50	400	65	90	160	9	80	92
3104R40	1600	5x140	250x40	420	160	200	13x21	50	400	65	90	160	9	80	93
4041R40	1600(2)	5x140	250x40	470	160	200	13x21	50	400	65	90	160	9	80	94
3932R40	1800(1)	5x112	250x40	475	160	200	13x21	50	400	65	90	160	9	80	92
3077R40	1800	5x140	250x40	420	160	200	13x21	50	400	65	90	160	9	80	93
3774R40	1800(2)	5x140	250x40	470	160	200	13x21	50	400	65	90	160	9	80	94

(1) : Pour roue 155/70 R12 - 5x112-20

(2) : Pour roue 195/50 R13 - 5x140-30

TOUS NOS ESSIEUX SONT ÉQUIPÉS DE FREINS KNOTT (homologués T.Ü.V.)

ESSIEUX FLEXIBLES FREINÉS

BRAKED FLEXIBLE AXLES

de 750 kg à 1300 kg



*Particulièrement recommandé
pour applications difficiles
(TP, militaire, etc...)*

*Particularly recommended
for special applications
(Construction, military, ...)*



Longueur à la demande

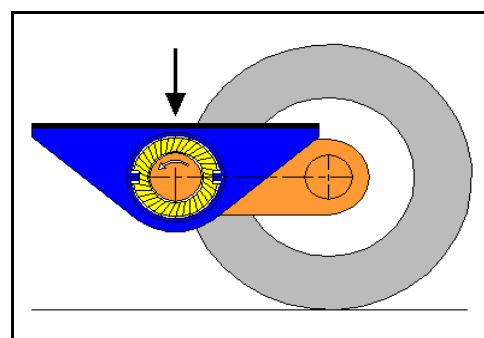
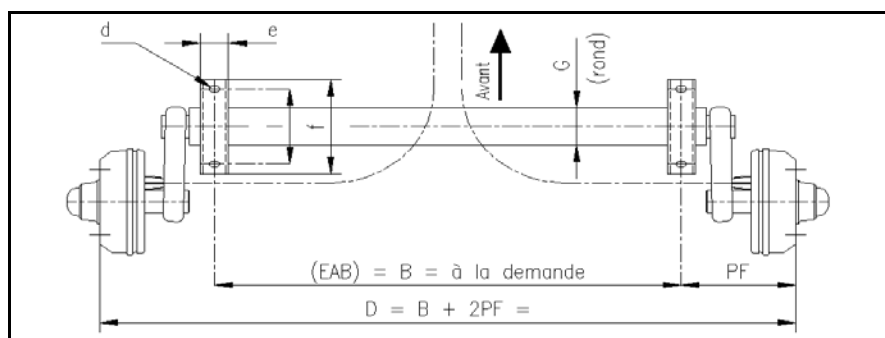
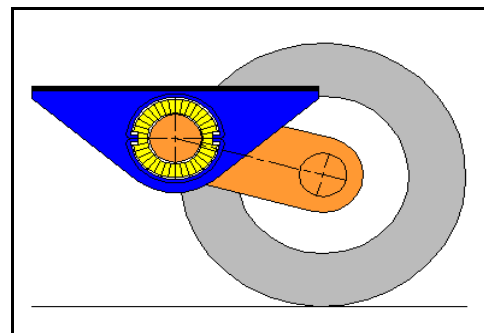
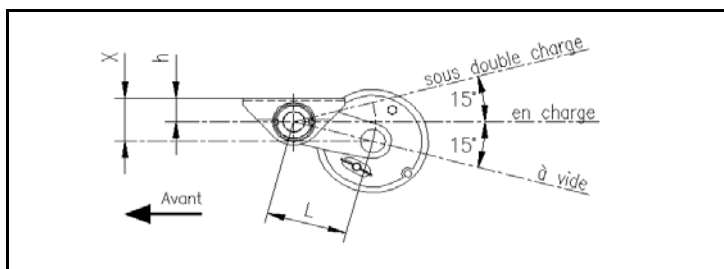

RÉF.	CHARGE kg	MOYEU Perçage	FREIN	2PF mm	BRIDE					X mm	Bras L	Corps G	Poids kg
					l	d	e	f	h				
2767R56	750	4x130	160x35	430	160	13x21	55	200	50	91	160	82	48
2768R56	850	4x130	160x35	430	160	13x21	55	200	50	91	160	82	48
2769R47	1000	4x130	200x50	450	160	13x21	55	200	50	91	160	82	52
2770R47	1300	4x130	200x50	450	160	13x21	55	200	50	91	160	82	52
2771R47	1300	5x140	200x50	450	160	13x21	55	200	50	91	160	82	52

PERÇAGES 4x100 et 5x112 : SUR DEMANDE

TOUS NOS ESSIEUX SONT ÉQUIPÉS DE FREINS KNOTT (homologués T.Ü.V.)

ESSIEUX FLEXIBLES FREINÉS

BRAKED FLEXIBLE AXLES

de 1500 kg à 3500 kg



*Particulièrement recommandé
pour applications difficiles
(TP, militaire, etc...)*

*Particularly recommended
for special applications
(Construction, military, ...)*



Longueur à la demande

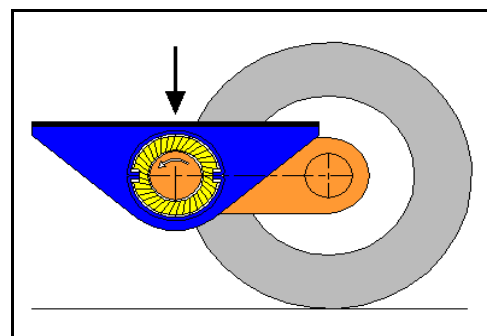
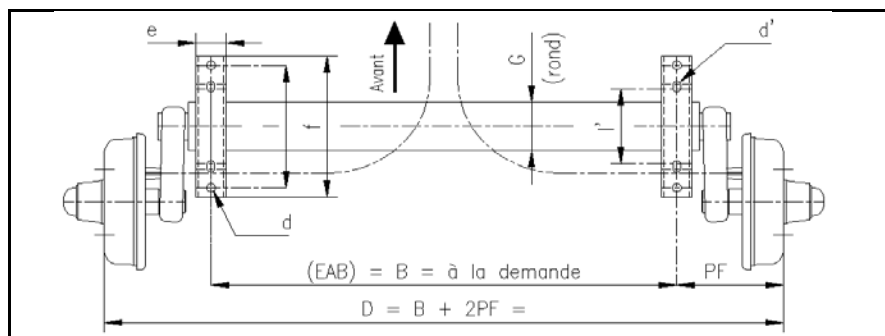
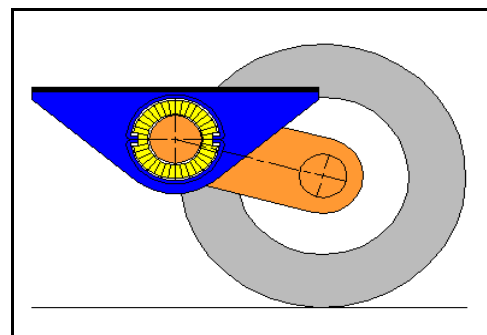
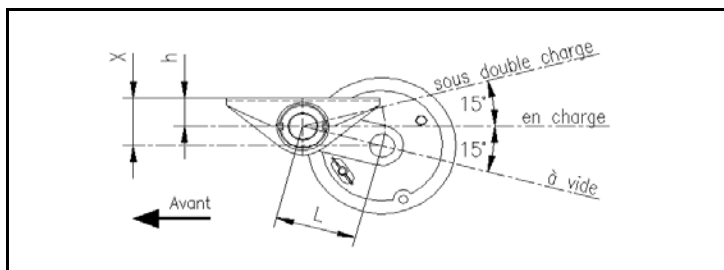

RÉF.	CHARGE kg	MOYEU Perçage	FREIN	2PF mm	BRIDE							X mm	Bras L	Corps G	Poids kg
					l	l'	d	d'	e	f	h				
2772R47	1500	5x140	200x50	450	260	160/180	18.5	14.5	60	300	60	101	160	103	65
2941R40	1600(1)	5x112	250x40	475	260	160/180	18.5	14.5	60	300	60	101	160	103	80
2773R40	1600	5x140	250x40	420	260	160/180	18.5	14.5	60	300	60	101	160	103	80
2774R40	1800	5x140	250x40	420	260	160/180	18.5	14.5	60	300	60	101	160	103	90
2775R40	1800(2)	5x140	250x40	420	260	160/180	18.5	14.5	60	300	60	99	150	103	95
2776R49	2000	5x140	300x60	470	260	160/180	18.5	14.5	60	300	60	99	150	103	100
2777R49	2500	6x205	300x60	470	260	160/180	18.5	14.5	60	300	60	91	120	103	110
2778R49	3000	6x205	300x60	510	280	160	18.5	18.5	80	320	71	102	120	103	130
3336R64	3500	6x205	300x80	720	Plan sur demande - Nous consulter							169	190	158	240

(1) : Pour roue 155/70R12 - 5x112-20

(2) : Essieu renforcé avec corps 2T (G20S)

TOUS NOS ESSIEUX SONT ÉQUIPÉS DE FREINS KNOTT (homologués T.Ü.V.)

ESSIEUX CARRÉS (ou TUBES) ROUTIERS

HIGH SPEED BEAM AXLES

de 1500 kg à 3000 kg

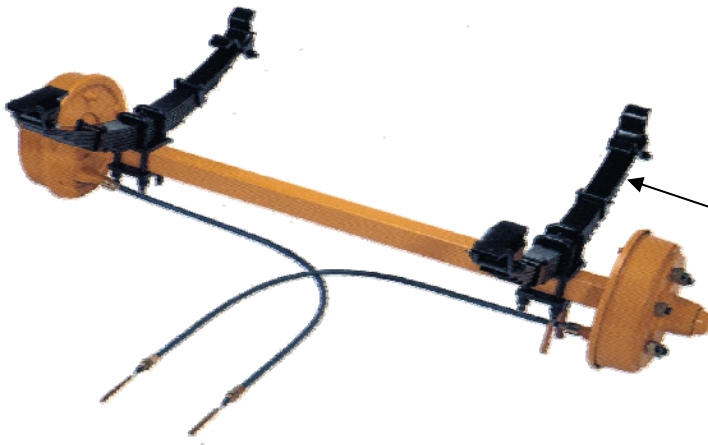

ATTENTION !
Nos essieux sont livrés sans ressorts

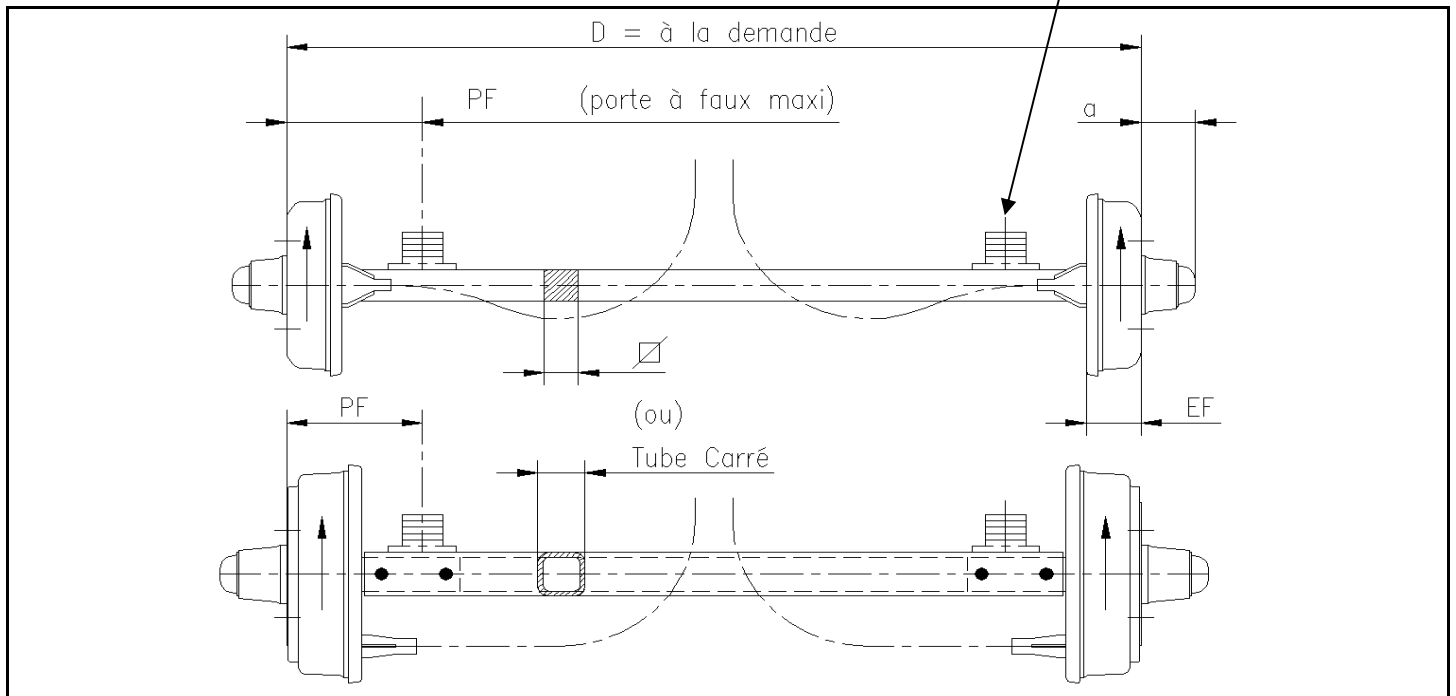

RÉF.	CHARGE kg	MOYEU Perçage	Corps Carré ou Tube	PF (maxi) mm	FREIN	a mm	EF mm	Poids kg
2732R47	1500	5x140	Carré 45	180	200x50	65	90	45
1061R40	1800	5x140	Carré 50	200	250x40	80	81	61
3553R49.TU	2500	5x140	Tube 70x70x8	250	300x60	99	111	88
3554R49.TU	2500	6x205	Tube 70x70x8	250	300x60	103	107	88
3555R49.TU	3000	6x205	Tube 70x70x8	200	300x60	116	123	100

NOTA : Poids approximatifs donnés pour D=1500 - Vis de roue M14x1,50 sauf pour 6x205 : Axes M18x1,50 DIN

(jusqu'à 1800 kg) PERÇAGE 5x112 : SUR DEMANDE

TOUS NOS ESSIEUX SONT ÉQUIPÉS DE FREINS KNOTT (homologués T.Ü.V.)

CÂBLES DÉTACHABLES

"QUICK FIT" CABLE SYSTEM



Les essieux sont livrés avec câbles séparés à monter suivant croquis ci-dessous.

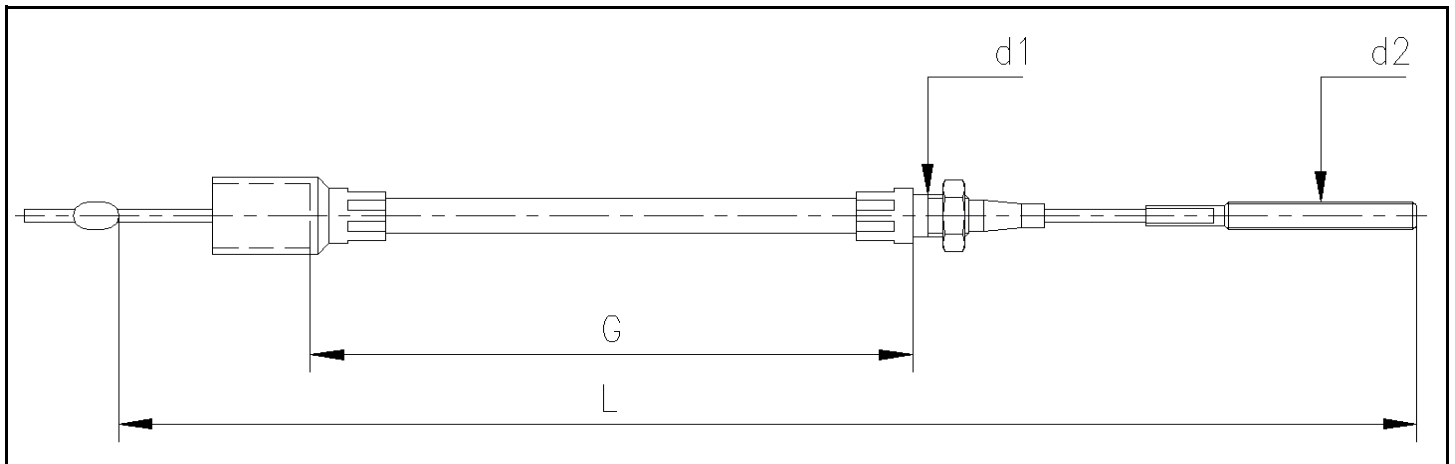
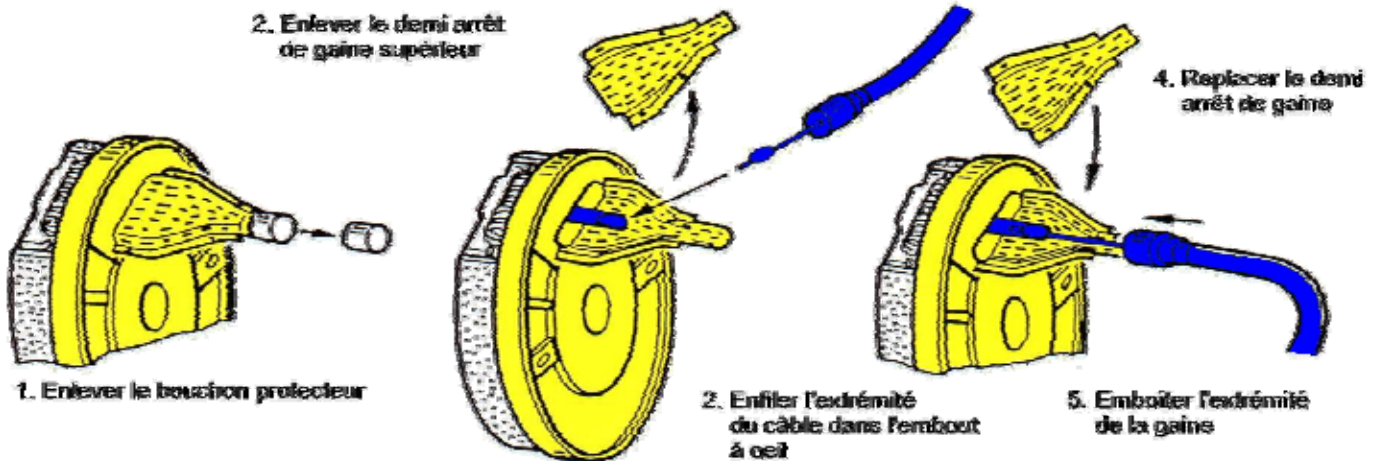

POUR FREINS Ø160x35 - Ø200x50 - Ø203,2x40 - Ø250x40

RÉF.	L mm	G mm	Voie mini essieu mm	Voie maxi essieu mm	d1 mm	d2 mm
2400001	1440	1230	2000	2300	M12x1.50	M8
2400002	1240	1030	1600	2000	M12x1.50	M8
2400003	1040	830	1300	1600	M12x1.50	M8
2400004	940	730	-	1300	M12x1.50	M8
2400005	1640	1430	Pour essieu AR Tandem		M12x1.50	M8
2400007	2040	1830	-	-	M12x1.50	M8

POUR FREINS Ø300x60 - Ø300x80

RÉF.	L mm	G mm	Voie mini essieu mm	Voie maxi essieu mm	d1 mm	d2 mm
2401001	1460	1200	D < 2000		M16x1.50	M10
2401002	1660	1400	D > 2000		M16x1.50	M10

ACCESSOIRES TIMONERIE DE FREINAGE

BRAKE LINKAGE COMPONENTS



MONTAGE SIMPLE ESSIEU

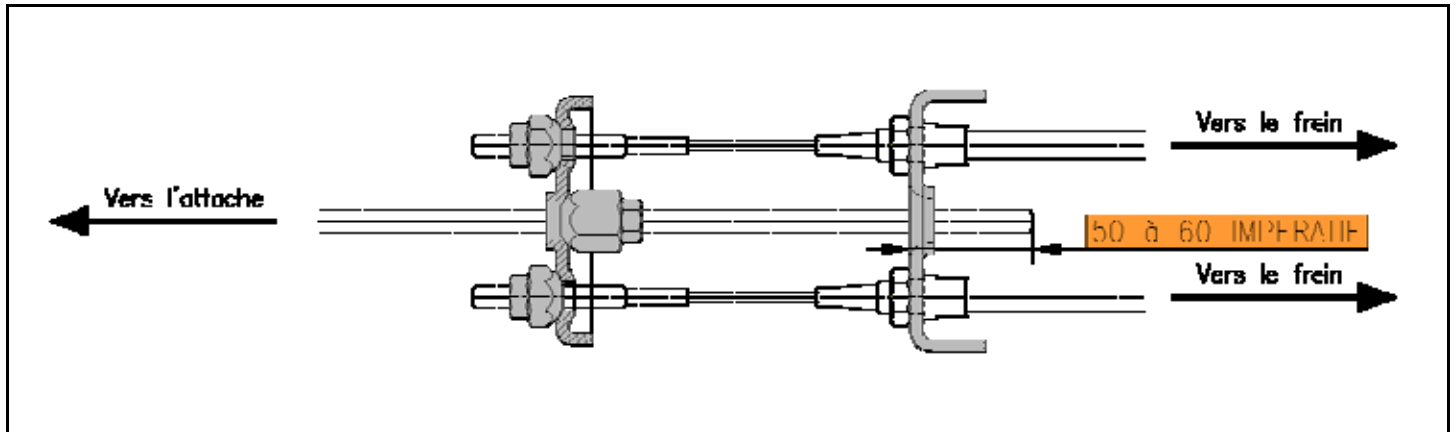

Pour freins \varnothing 160x35 - \varnothing 200x50 - \varnothing 203,2x40 - \varnothing 250x40

KIT PALONNIER SIMPLE Réf. 1000313

ARRÊT DE GAINE SIMPLE Réf. 1000277

Pour frein \varnothing 300x60

KIT PALONNIER SIMPLE Réf. 1000356

MONTAGE TANDEM

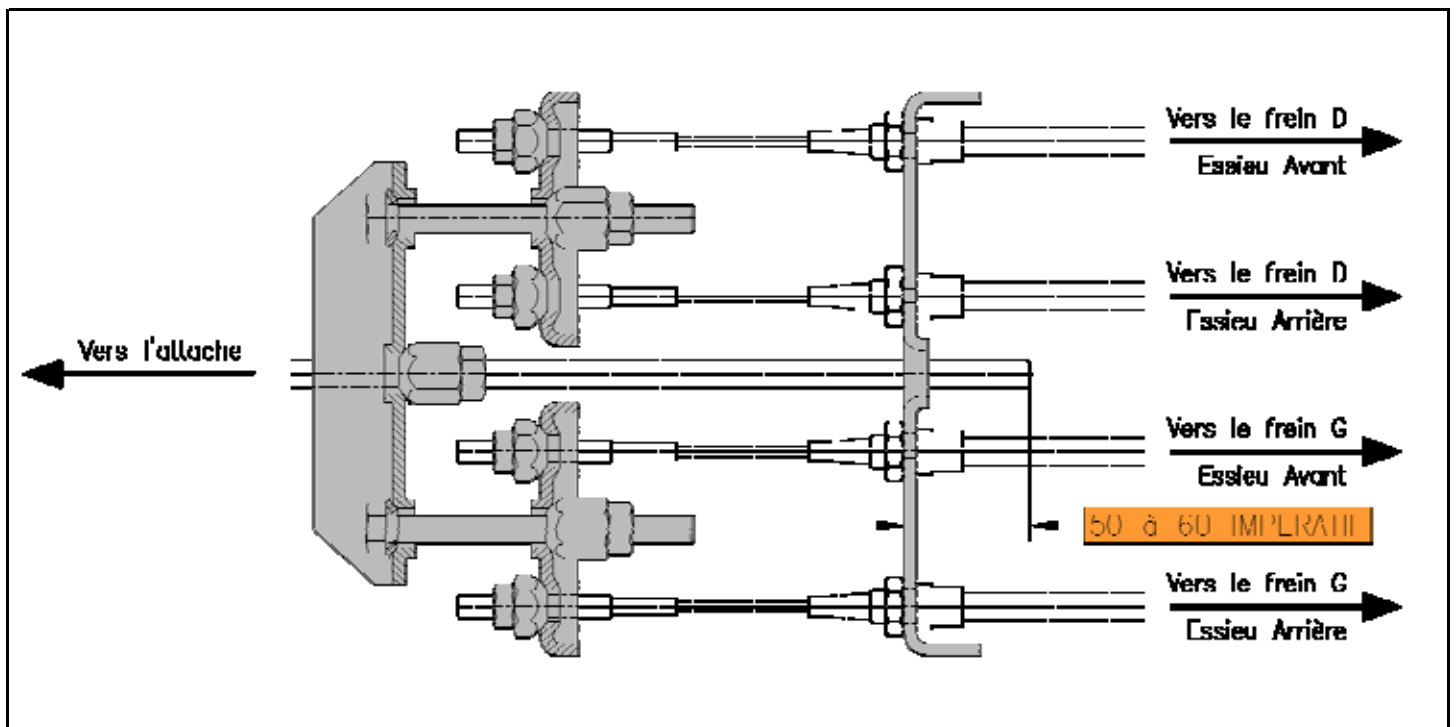

Pour freins \varnothing 160x35 - \varnothing 200x50 - \varnothing 203,2x40 - \varnothing 250x40

KIT PALONNIER DOUBLE Réf. 1000307

ARRÊT DE GAINE DOUBLE Réf. 1000314

TANDEM AVEC REPORT DE CHARGE OU ABAISSEMENT

UP AND DOWN OR COMPENSATION TANDEM AXLES SUSPENSIONS



SUR DEMANDE : nous consulter.

